

FREEMAN MARINE Dutch doors perform like a single panel door when regular access is needed, yet the top half can be operated separately from the bottom half to improve ventilation and visibility. Heavy duty doors feature thick panel skins, extra internal reinforcements, no exposed seams and all welded construction to create a rugged closure in individually dogged versions. Heavy duty panels feature a lineal brushed finish, a FREEMAN trademark that creates a durable, uniform texture. When specified with optional yacht-quality paint to your color specifications, the 1520 Series welded construction results in a smooth, seamless appearance that features long lasting beauty. Doors offer welded in windows and can accommodate special glazing. Solidly constructed and fully insulated, heavy duty Dutch doors are suitable for the following typical high traffic access installations:

- Pilothouse • Galley • Salon • Main Deck

**DUTCH, HEAVY-DUTY DESIGN FEATURES**

- Custom Sizing, width and height
- .160"~.250" Thick Aluminum Panel Skins
- Welded Frame and Skin Construction
- Gasket on Door Panel for Long Life and Positive Sealing
- Gasketed Joint Between Upper and Lower Panels
- Radius or Mitered Corners
- Bolt-in, Weld-in or Clamp-in Frames
- Added Internal Stiffeners
- Lineal Sanded Finish
Yacht-quality painted finish (avail)
- Stainless Steel Dog Shafts
- Cast Aluminum Handles, powder coat (opt avail)
- Glass Filled Striker Wedges
- Solid Insulation (opt materials avail)
- Stainless Steel Hinges (opt avail)
- Stainless Steel Fasteners
- Welded In Window, glazing and tint (opt avail)

Heavy Duty Dutch doors are custom fabricated to each applications specific needs.



Narrow window,
Wide access door,
Aluminum bolt in frame,
Painted



Clamp-in window,
Top panel open



Wide window,
Steel weld-in frame

Interior polished
hardware,
With roses,
Fixed stop



Interior satin
hardware,
Escutcheon plates,
Powder coated dogs



Panel top,
Edge detail



Oval window,
Polished hardware,
Bolt-in aluminum frame,
Painted



Large radius
window, Aluminum
weld-in frame,
To be yard painted



Window,
Steel flange,
Bolt-in



Widest upper
half window,
Polished dogs,
Aluminum
weld-in frame, Painted

Panel bottom,
Sealing detail



Hinge,
Bolt-on ,
(Use w/ fixed stop),
Polished finish



Hinge, Bolt-on,
(Use w/ adjustable stop),
Satin finish



Knuckle, Dutch, Sundeck,
Flybridge, Closed



Knuckle,
Dutch, Open



Knuckle, Dutch,
View port, Open



Knuckle, Dutch,
View port, Open

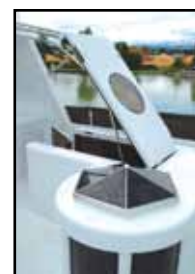

Knuckle, Dutch,
Installed, (Note skylight
top and locker door)



Knuckle,
Dutch,
View port



Knuckle,
Dutch,
Flybridge,
Installed



Knuckle,
Dutch,
Two styles

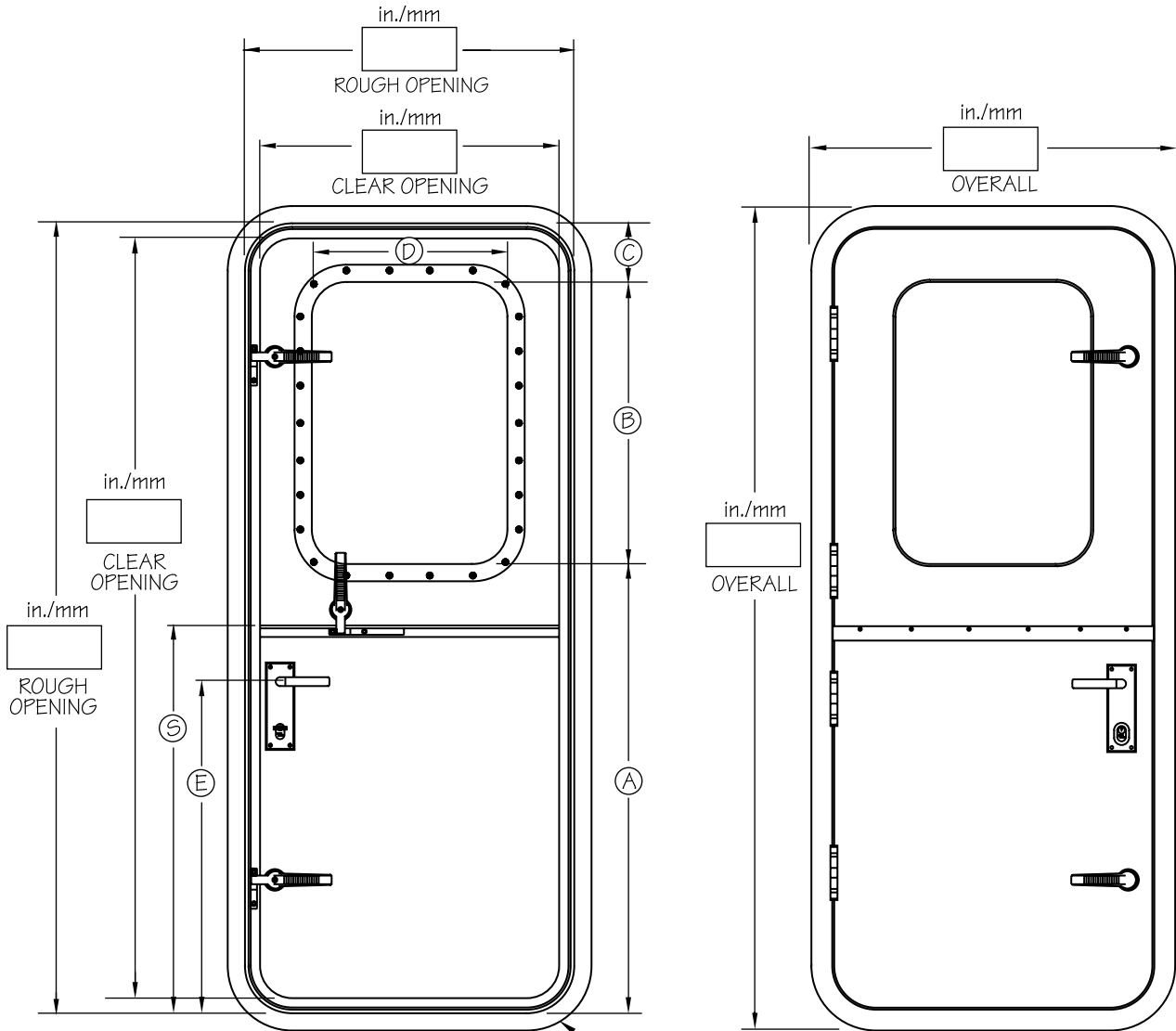

INTERIOR

EXTERIOR

CORNERS
RADIUS
MITERED

Dimensions For options		
inches	mm	
A		Bottom of Clear Glass to Bottom Rough Opening
B		Clear Glass Height
C		Top of Clear Glass to Top of Rough Opening, min 7"
D		Clear Glass Width, min side clearance 6"
E		Handle/Lockset - C/L to Bottom Rough Opening
S		Panel Split Height

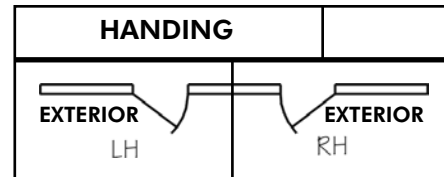

Scale None

© ALL RIGHTS RESERVED
2010 FREEMAN MARINE EQUIPMENT, INC.
SPECIFICATIONS SUBJECT TO CHANGE WITHOUT NOTICE

LAYOUT
MODEL 1520

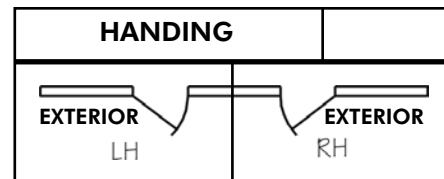
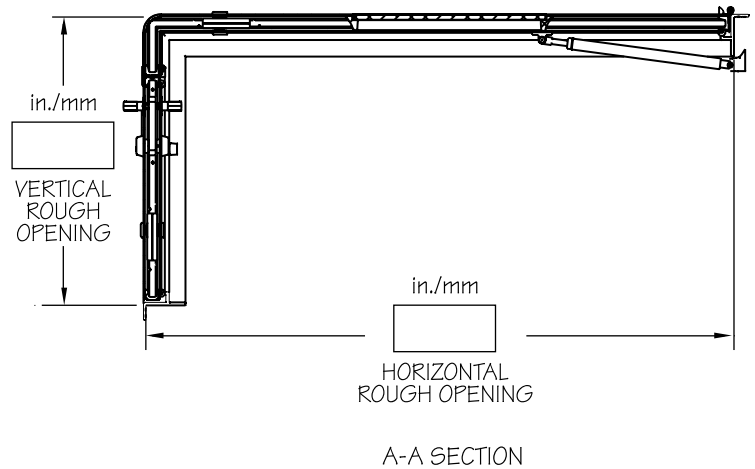
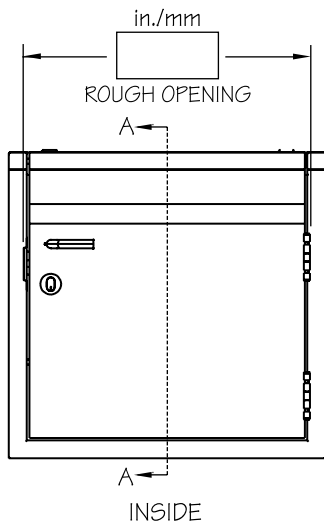
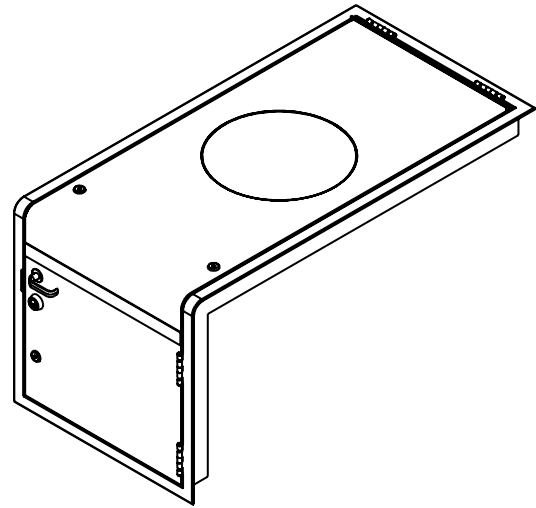
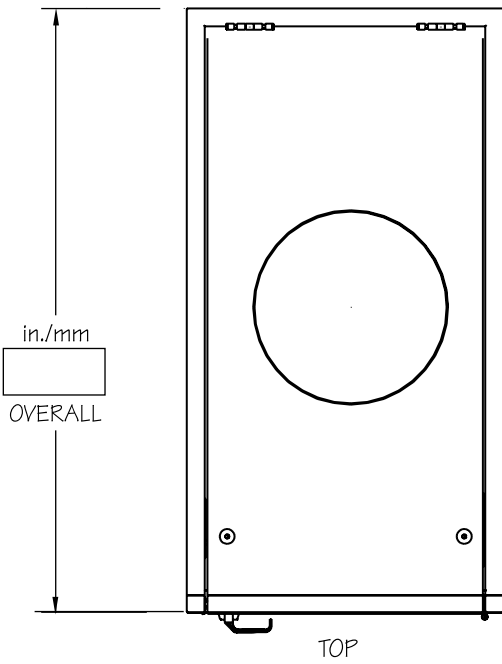

Scale	None
Option	Window

© ALL RIGHTS RESERVED
2010 FREEMAN MARINE EQUIPMENT, INC.
SPECIFICATIONS SUBJECT TO CHANGE WITHOUT NOTICE

LAYOUT
MODEL 1520

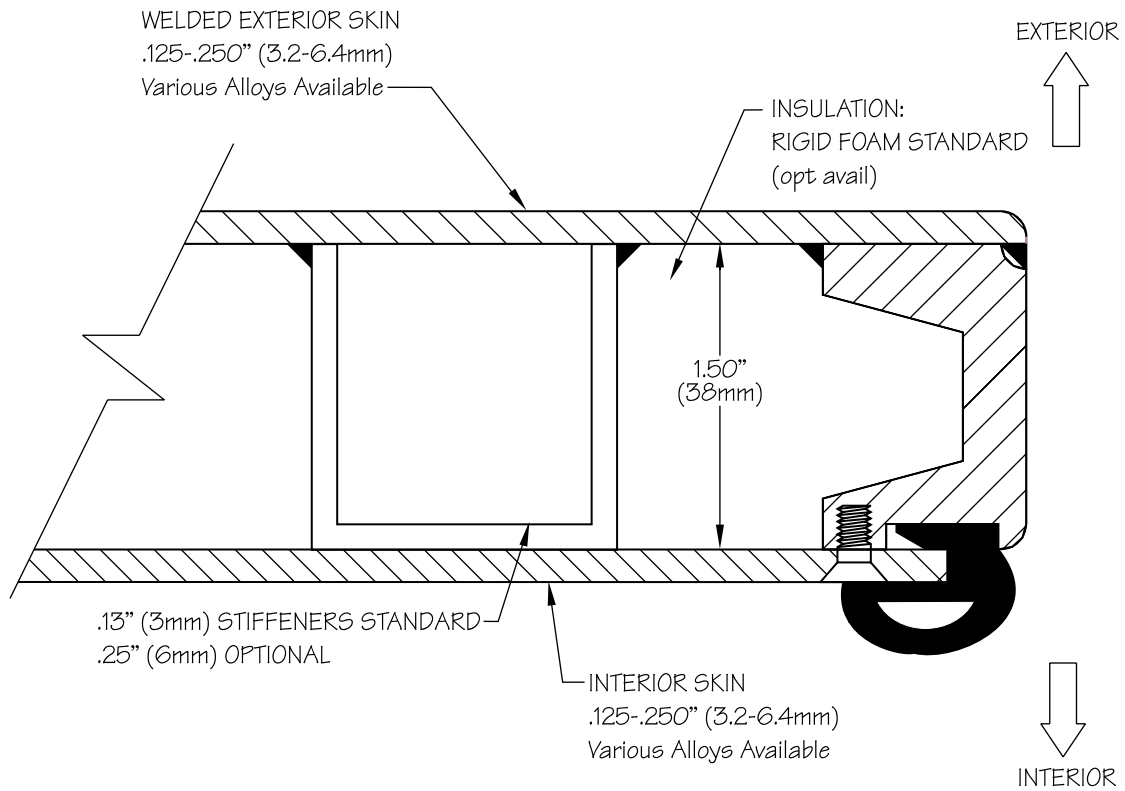
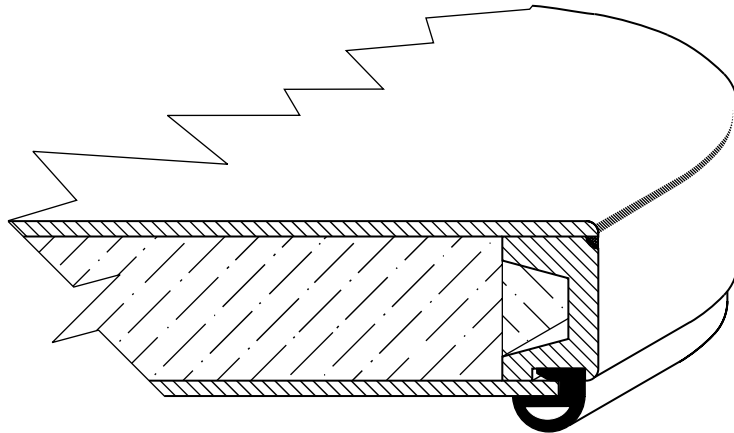

PANEL

Sealing Performance	Weather Tight		
Availability	1120 Single	1420 Quick-Acting	1520 Dutch
	1620 French	1720 Sliding Doors	

Degree of watertightness depends on panel and coaming construction, number of dogs, proper installation and sealing adjustment. Closures are individually defined, specified and fabricated for each application.

© ALL RIGHTS RESERVED
2010 FREEMAN MARINE EQUIPMENT, INC.
SPECIFICATIONS SUBJECT TO CHANGE WITHOUT NOTICE

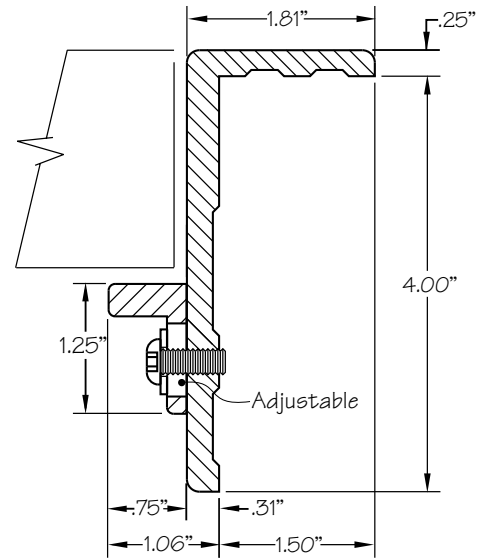
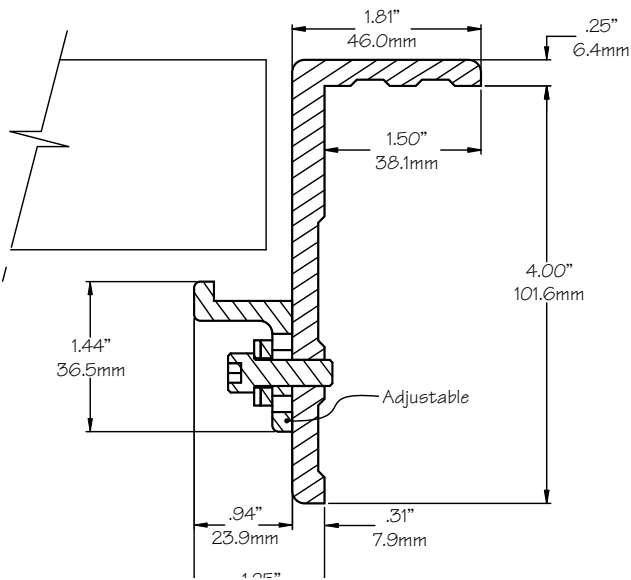
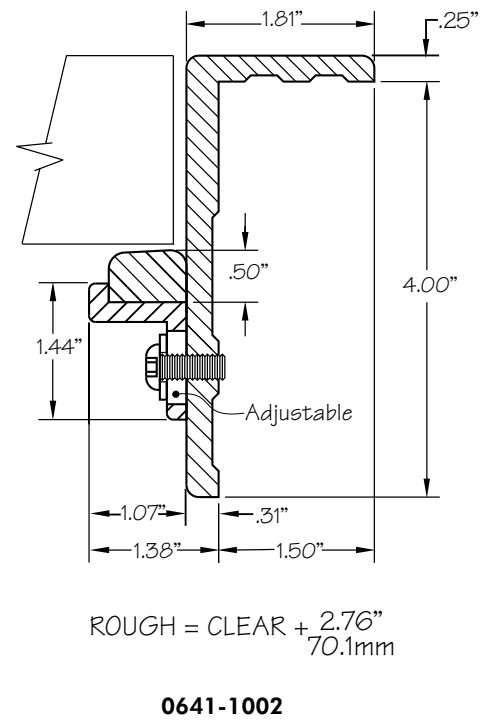
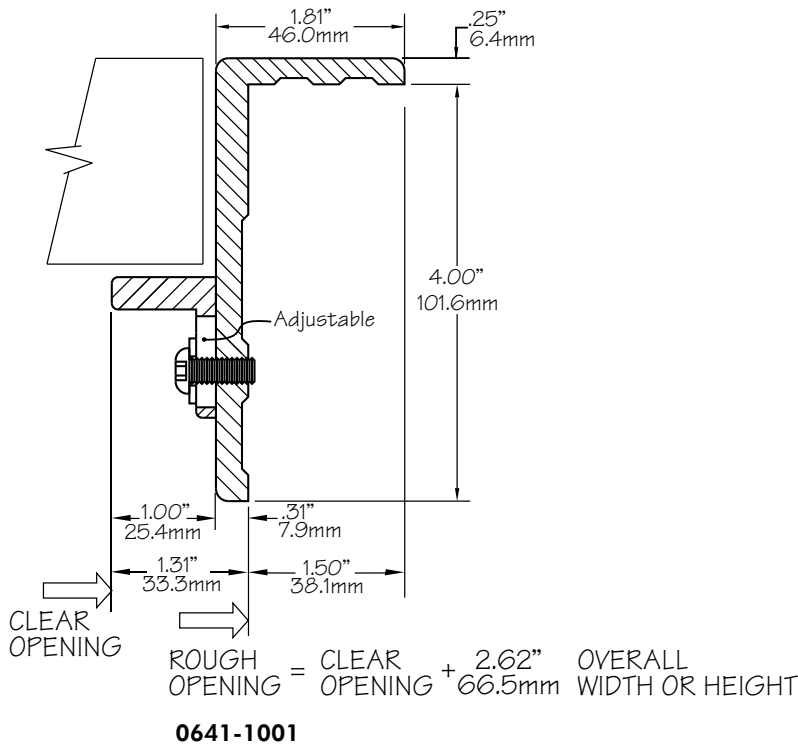

Coaming Assembly No.	0641-1001	0641-1002	0641-1003	0641-1051	Degree of watertightness depends on panel and coaming construction, number of dogs, proper installation and sealing adjustment. Closures are individually defined, specified and fabricated for each application.
Gasket Seal Stop Type	1" Wide Flat	Gasket in Frame	3/4" Wide Flat	Gasket in Frame	
Coaming Material	Aluminum				
Coaming Configuration	Extrusion w/ Flange				
Stop Type / Material	Adjustable / Aluminum				
© ALL RIGHTS RESERVED 2010 FREEMAN MARINE EQUIPMENT, INC. SPECIFICATIONS SUBJECT TO CHANGE WITHOUT NOTICE					

COAMING

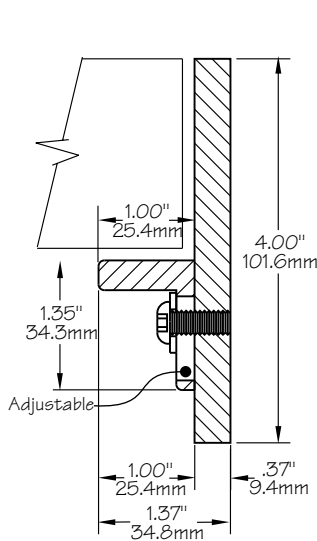

Aluminum - Flat Bar, 4.0" x .38", No Flange
 Stop - Adjustable, 1.0" wide
0641-1004

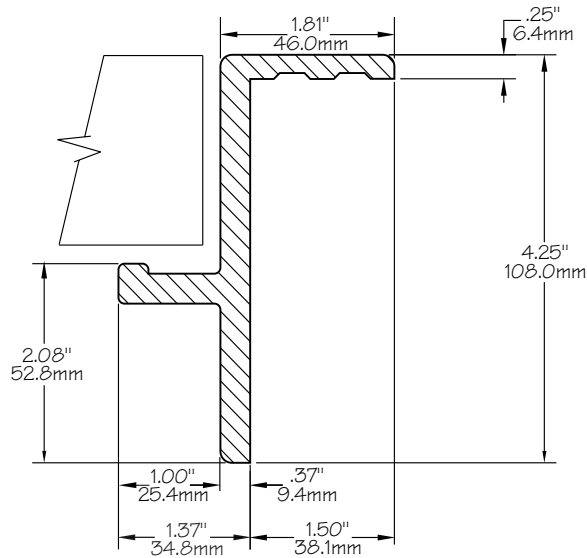

Aluminum - Angle Extrusion, 4.25" x 1.81", Flange
 Stop - Fixed
0641-1007

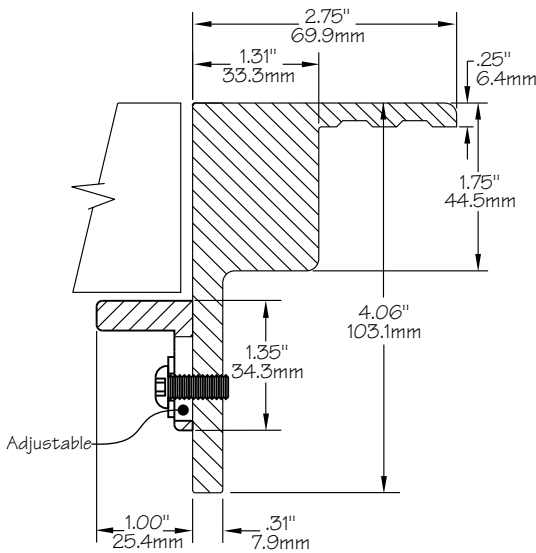

Aluminum - Custom Extrusion, 4.06" x 1.31"+1.44",
 w/ Flange & heavy section for Dog Engagement
 Stop - Adjustable, 1.00" wide
0641-1008

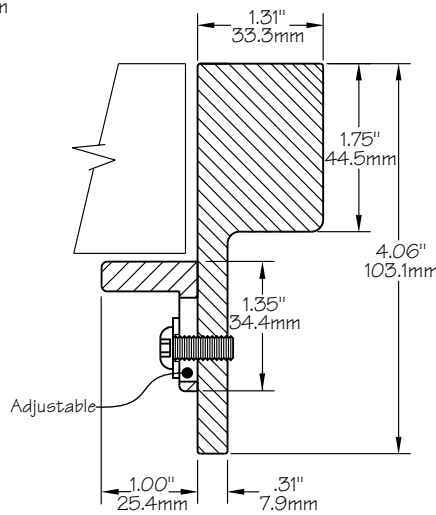

Aluminum - Custom Extrusion, 4.06" x 1.31",
 No Flange & heavy section for Dog Engagement
 Stop - Adjustable, 1.00" wide
0641-1011

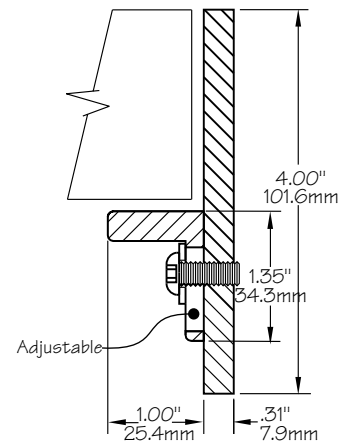

Steel - Flat Bar, 4.00" x .32",
 Stop - Adjustable - 1.00" wide
0641-1028

COAMING

Degree of watertightness depends on panel and coaming construction, number of dogs, proper installation and sealing adjustment. Closures are individually defined, specified and fabricated for each application.

© ALL RIGHTS RESERVED
 2010 FREEMAN MARINE EQUIPMENT, INC.
 SPECIFICATIONS SUBJECT TO CHANGE WITHOUT NOTICE

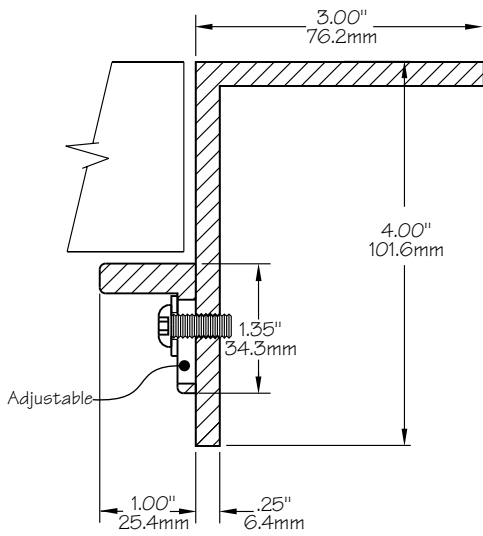

Steel - Angle, 4.00" x 3.00" x .25",
 Stop - Adjustable, 1.00" wide
0641-1031

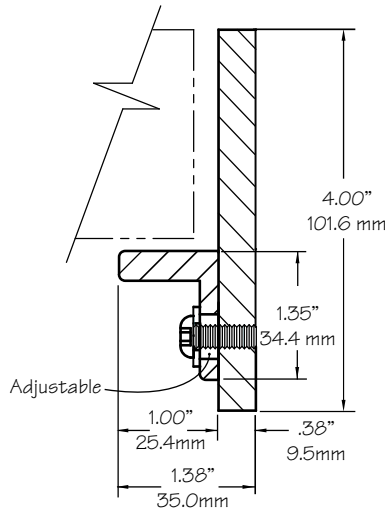

Stainless Steel - Flat Bar 4.00" x 3/8"
 Stop - Adjustable, 1.00" wide - Aluminum
0641-1046

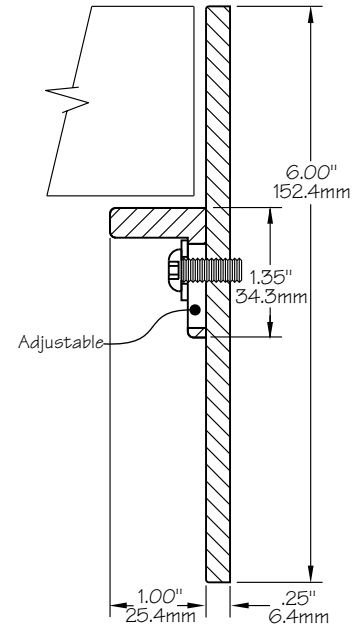

Stainless Steel - Flat Bar 6.00" X .25",
 Stop, Adjustable - 1.00" wide
0641-1022

Degree of watertightness depends on panel and coaming construction, number of dogs, proper installation and sealing adjustment. Closures are individually defined, specified and fabricated for each application.

© ALL RIGHTS RESERVED
 2010 FREEMAN MARINE EQUIPMENT, INC.
 SPECIFICATIONS SUBJECT TO CHANGE WITHOUT NOTICE